

NPoDAS

Portable GIS Partial Discharge Diagnostic System

Hanbit

Smart Diagnostic Solution

Product Descriptions

Gas Insulated Switchgear is safe, compact, stable and easier to setup indoor or outdoor comparing conventional switchgears. The system deterioration caused by thermal, electrical, mechanical and environmental aging might lead to serious accidents but not be visible from outside.

PoDAS enables to monitor UHF signals from GIS, diagnose types of PD and analyze the PD location accurately. The accuracy of PD analysis algorithm was proven by field operators.

Utilizing noise sensor and band rejection filter enables isolating ambient noise efficiently. User-friendly HMI and self-explanatory functions benefit users to diagnose and analyze GIS Partial Discharges effortlessly.

GIS Partial Discharge (Particle) Sample

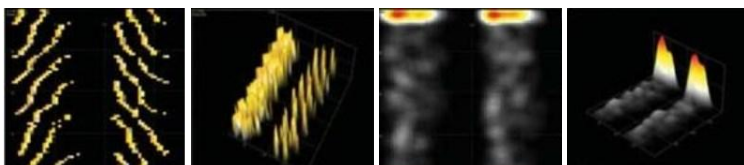

2D PRPS

3D PRPS

2D PRPD

3D PRPD

Noise Signals Sample

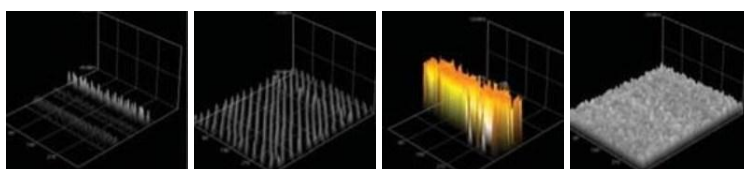

Radar

Airplane

Circuit Breaker

CellPhone

IN-SERVICE MEASUREMENT

- Real-time PRPS 2D/3D, PRPD 2D/3D Display
- Real-time noise elimination
- Measuring each channel simultaneously
- Saving data automatically and periodically (0.5, 1, 5, 10, 30 min, 1 hour and infinite)
- Phase Shift Function
- Real-time Analysis

ANALYSIS FUNCTIONS AND REPORTING

- Building Database by location and date
- Reviewing saved diagnosis data
- Displaying signal trend with PD types and amplitude
- Analyzing signal amplitude and phase in PRPS/PRPD 2D/3D
- Eliminating noise signal using noise sensor
- Shifting phase
- Various reports

DIAGNOSTIC SOFTWARE

- Highly accurate PD analysis algorithm proven by field operators
- Analyzing the signal into Particle, floating, Corona, Void or Noise, irrespective of the phase
- Screen captures of PD and noise signals in the diagnostic software library

SUPPLY RECORD

- KEPCO (Korea Electric Power Corporation)
- Korea Water Resources Corporation
- Samsung Corning Precision Materials
- SK Energy
- Air Products Korea Inc. (APCI Inc.)
- Malaysia, China etc.



Specification

System Diagram

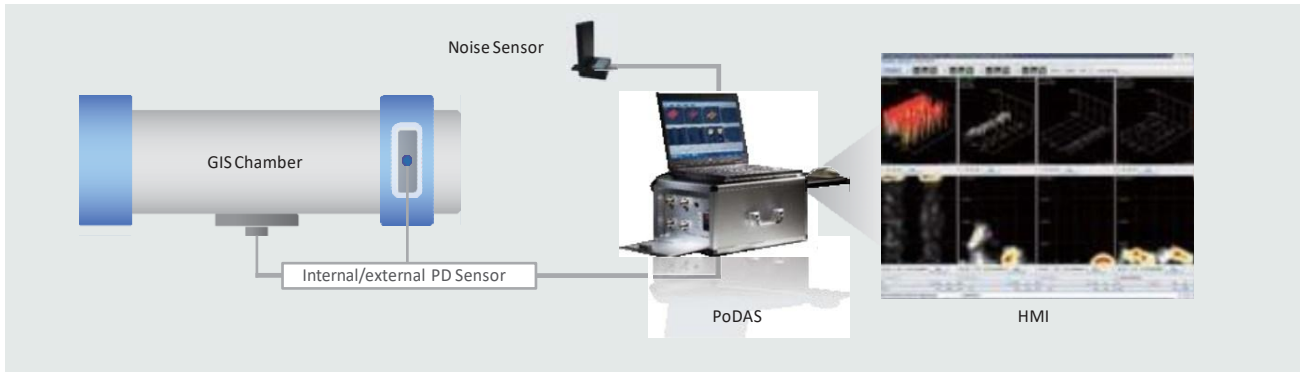

Technical Specification

System Configuration

NPoDAS	Receiving and processing signal, transmitting data
Laptop Computer	Running Diagnosis Software
Diagnosis Software	Eliminating noise and analyzing PD signal
External PD Sensor	Detecting signals from inside of GIS
Noise Sensor	Detecting ambient noise signals
Band Rejection Filter	Eliminating preset UHF bandwidth
Cable	Coaxial, Power, LAN

NPoDAS

Input Channels	4 channels (1 channel for noise sensor)
Supply Voltage	85~264Vac, 50/60Hz 260 μ s
Sampling Time	(128sample/1cycle)
Communication	UDP/IP
Detection Bandwidth	500~1,500 MHz
Min. Pick-up Level	-65 dBm
Sync	Source Voltage
NPoDAS Package	PoDAS + Laptop + S/W + UHF PD Sensor(4) + Noise Sensor(1) + BRF(4) + LMR400UF(4)
Dimensions	Main Case: 450(W) x 350(D) x 270 (H) (\pm 5%) [mm]

Specification

Laptop Computer

CPU	2GHz Dual Core or above
RAM	1GB or above
Hard Disk	500GB or above
Operating System	Windows 10 or above

External GIS PD Sensor

Detection Bandwidth	500 ~ 1,500 MHz
Sensor Sensitivity	-40dBm @5pC
Max Output	-26dBm
Connector	N-type connector
Installation	Spacer of GIS

Noise Sensor

Detection Bandwidth	300 ~ 3,000 MHz
Connector	N-type connector
Installation	Place on top of GIS (Using magnetic force of sensor)

Test Reports

Environment Test

Cold Test	IEC 60068-2-1(Test A: Cold)
Dry Heat Test	IEC 60068-2-2(Test B: Dry heat)
Temperature/Humidity Cyclic Test	IEC 60068-2-30 (Test Db: Damp heat, cyclic (12 h + 12 h cycle))
Vibration Test	IEC 60068-2-6(Test Fc: Vibration (sinusoidal))
Separate-Source Voltage Withstand Test	IEC 60947-5-2, clause 8.3.3.4
Lightning Impulse Withstand Voltage Test	IEC 60947-5-2, clause 7.2.3.1

Electro-Magnetic Susceptibility Test

Electrostatic Discharge Immunity Test	KS C IEC 61000-4-2
Radiated RF Electromagnetic Field Immunity Test	KS C IEC 61000-4-3
Electrical Fast Transient/Burst Immunity Test	KS C IEC 61000-4-4
Surge Immunity Test	KS C IEC 61000-4-5
Immunity to Conducted Disturbans, Induced by Radio-Frequency Field Test	IEC 61000-4-6

NPoDAS Package

<p>NPoDAS with Lapto</p>		<ul style="list-style-type: none"> - N PoDAS: Calculate and process PD signals and transmit data to diagnostic program aptop: Operating a program that performs signal analysis and diagnosis ower: 85~265VAC, 60/50Hz equency Range: 500~1,500MHz put: PD Sensor – 3 Ch Noise sensor – 4 Ch - Communication: UDP/IP Protocol
<p>Diagnosing Software</p>		<ul style="list-style-type: none"> - Analyzing and diagnosing PD types and noise by type - Real-time PRPS, 3D/2D display and analysis by synchronizing with power phase - S/W option settings: standard value, report writing, phase shift - Built-in libraries and noise signals for each type of PD - Data storage and report function
<p>External UHF PD Sensor</p>		<ul style="list-style-type: none"> - Measurement range: 500 ~1,500 MHz - Mounting method: fixed to GIS spacer - Connector: N-Type
<p>Noise Sensor</p>		<ul style="list-style-type: none"> -Measurement range: 300 ~3,000MHz - Mounting method: Magnet type, mounted around GIS equipment - Connector: N-Type
<p>Band Rejection Filter</p>		<ul style="list-style-type: none"> - For removing surrounding noise such as communication noise - Mounting method: Connected to the input channel of diagnostic equipment
<p>Accessories Case</p>		<ul style="list-style-type: none"> - accessory storage box - Coaxial cable: LMR400UF 15m, 4 sets - 1 set each of power cable and LAN cable

Case Study

PD Diagnosis Case

- Site: KEPCO ## Substation 154kV GIS
- Tool: NPoDAS
- Result: Floating PD

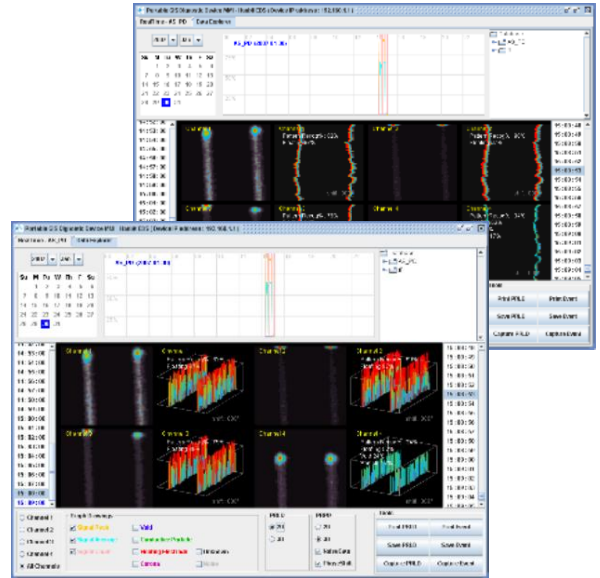
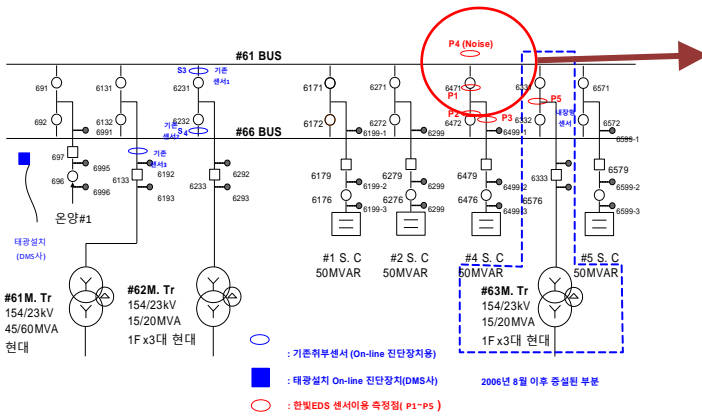

PD Waveform Examples

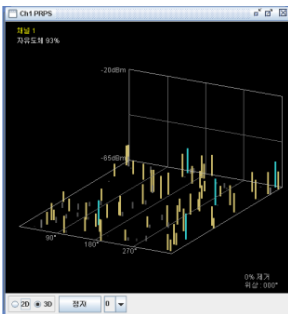

Particle

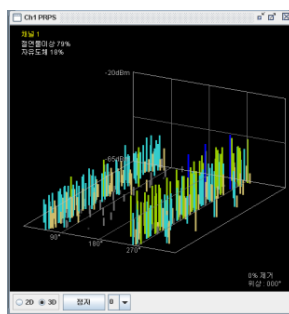

Void

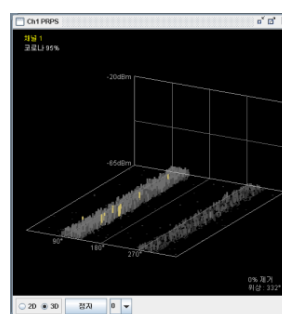

Corona

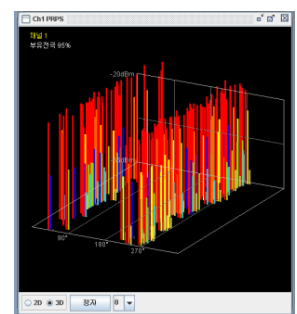

Floating

NPoDAS - Tx

Transformer

On-line Monitoring System

Transformer On-line PD monitoring

Transformer PD monitoring system for detecting and diagnosing faults accelerating deterioration

Local Unit & PD Diagnostic Device



- Standardize data acquired from UHF sensors(PD/Noise) and transmit data to Diagnosing Unit
- Input : Max. 32 Ch(PD/Noise)
- Frequency : 300~1,800 MHz
- Lower Limit of Detection : under -55 dBm(0.003 μ W)

UHF PD Sensor (Internal/External)

- Frequency : 300~1,800 MHz
- Sensitivity : <100 pC (IEC60270)



Window Sensor



Noise Sensor

UHF Noise Sensor

- Frequency : 300~3,000 MHz

Transformer PD types

